

DICHIARAZIONE DI PRESTAZIONE

ai sensi del Regolamento (UE) n. 305/2011

N° 0064

1. Codice identificativo unico del prodotto tipo: **0064 – Connettore CentroStorico Legno**
2. Uso previsto del prodotto da costruzione: **Connettori per utilizzo in solette miste legno-calcestruzzo**
3. Nome e indirizzo del Fabbricante:
LATERLITE S.p.A.
Via Vittorio Veneto, 30
43046 Rubbiano di Solignano (PR)
Plant I
4. Rappresentate autorizzato: **Non applicabile**
5. Sistema AVCP: **1**
6. Documento per la valutazione europea: **EAD 130090-00-0303 “Wood-concrete composite slab with dowel-type fasteners”**
Valutazione tecnica europea: **ETA-19/0297; 2024-08-02**
Organismo di valutazione tecnica: **ETA-Danmark A/S**
Organismo notificato: **n. 1034 - HFB Engineering GMBH**
7. Prestazioni dichiarate:

Caratteristiche essenziali	Prestazione
Materiale e geometria	Vedi Annex 1 ETA-19/0297 allegato
Rigidezza meccanica e resistenza a taglio	Vedi Annex 2 ETA-19/0297 allegato
Protezione alla corrosione	Le viti sono realizzate in acciaio come specificato nel piano di controllo e protette con un rivestimento in zinco.
Reazione al fuoco	Classe A1

La prestazione del prodotto sopra identificato è conforme all'insieme delle prestazioni dichiarate. La presente dichiarazione di responsabilità viene emessa in accordo al Regolamento UE N 305/2011 sotto la sola responsabilità del fabbricante sopra identificato.

Firmato a nome e per conto del fabbricante da:
Ing. Massimo Nicolosi, Responsabile Qualità

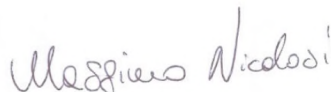

Rubbiano, 02 Settembre 2024, rev.02



ETA-Danmark A/S
Göteborg Plads 1
DK-2150 Nordhavn
Tel. +45 72 24 59 00
Fax +45 72 24 59 04
Internet www.etadanmark.dk

Authorized and notified according
to Article 29 of the Regulation (EU)
No 305/2011 of the European
Parliament and of the Council of 9
March 2011

MEMBER OF EOTA



European Technical Assessment ETA-19/0297 of 2024/08/02

General Part

Technical Assessment Body issuing the ETA and designated according to Article 29 of the Regulation (EU) No 305/2011: ETA-Danmark A/S

Trade name of the
construction product:

LATERLITE CONNETTORE CENTROSTORICO
LEGNO connectors

Product family to which the
above construction product
belongs:

Fasteners for use in wood-concrete slab kits

Manufacturer:

Laterlite S.p.A
Via Vittorio Veneto 30
IT-43046 Rubbiano di Solignano (Parma)
Tel.: +39 0525-41 98
Internet: www.laterlite.com

Manufacturing plant:

Laterlite S.p.A
Manufacturing Plant I

This European Technical
Assessment contains:

16 pages including 3 annexes which form an integral
part of the document

This European Technical
Assessment is issued in
accordance with Regulation
(EU) No 305/2011, on the
basis of:

European Assessment Document (EAD) no EAD
130090-00-0303 "Wood-concrete composite slab with
dowel-type fasteners"

This version replaces:

The ETA with the same number issued on 2022-05-17

Translations of this European Technical Assessment in other languages shall fully correspond to the original issued document and should be identified as such.

Communication of this European Technical Assessment, including transmission by electronic means, shall be in full (excepted the confidential Annex(es) referred to above). However, partial reproduction may be made, with the written consent of the issuing Technical Assessment Body. Any partial reproduction has to be identified as such

II SPECIFIC PART OF THE EUROPEAN TECHNICAL ASSESSMENT

1 Technical description of product

This ETA is an assessment of the LATERLITE CONNETTORE CENTROSTORICO LEGNO connectors for wood-concrete composite slab kits. The assessment concerns use of the screws in composite slab kits, however, the holder of this ETA only delivers the complete connectors (prismatic part and screw).

Shape and tolerances of the connectors are given in Annex 1.

The kits are individually designed to meet the requirements put on the works.

Laterlite S.p.A. delivers the connectors for the composite action to be used as kit components. The composite members may be prefabricated at factory, or they may be composed at the building site. The proper function of the wood-concrete composite slabs provides for the following components to be added in the factory or at the building site:

- Concrete slab, according to EN 206-1, and reinforcement according to EN 10080 and national regulations either prefabricated or cast at the building site.
- In the case of concrete cast at the building site: formwork, e.g. timber boards or wood based panel. This is an optional intermediate layer between the concrete and the timber. When the concrete slabs are prefabricated, no intermediate layer between timber and concrete is needed.
- In the case of concrete cast at the building site: lateral moulding along the edges of the slab.
- Timber members, e.g. glulam according to EN 14080, sawn softwood timber according to EN 14081-1, LVL according to EN 14374 or cross laminated timber according to ETA.

The concrete slab is generally stressed at combined compression and bending while the timber beam is stressed at combined tension and bending.

This ETA covers connectors for composite members with minimum concrete flange depths of 40 mm and minimum timber member depths of 80 mm. The maximum concrete flange depth is 1.5 times the timber member depth. Typical span widths for the construction are up to 8 m with sawn softwood timber members, 10 m with LVL members and 14 m with glulam members but larger span widths also are possible.

A typical composite member and connectors are shown in Annex 1.

2 Specification of the intended use in accordance with the applicable European Assessment Document (hereinafter EAD)

LATERLITE CONNETTORE CENTROSTORICO LEGNO connectors are intended to be used in structural composite members such as floor, roof, or wall constructions in service classes 1 and 2 as defined in EN 1995-1-1 subject to static or quasi static loading. In addition, use class 3.1 as defined in EN 335-1 (exterior, above ground, protected) may be possible, as balconies depending on national provisions.

The verification and assessment methods on which this European Technical Assessment is based lead to the assumption of a working life of at least 50 years for connectors.

The indications given on the working life cannot be interpreted as a guarantee given by the manufacturer, but are to be regarded only as a means for choosing the right product in relation to the expected economically reasonable working life of the works.

3 Performance of the product and references to the methods used for its assessment

Characteristic	Assessment of characteristic
3.1 Mechanical resistance and stability (BWR 1)*)	
Material and geometry	See Annex 1
Mechanical strength	<p>The screws are in accordance with EN 14592 with the following performance for Ø10 mm screws:</p> $f_{ax,k} = 10,30 \text{ N/mm}^2$ $f_{head,k} = 19,63 \text{ N/mm}^2$ $f_{tens,k} = 40,13 \text{ kN}$ $f_{tor,k} / R_{tor,k} = 2,76$ <p>No performance is assessed for Ø12 screws</p>
Mechanical stiffness and shear resistance	<p>Wood-concrete composite slabs including LATERLITE CONNETTORE CENTROSTORICO LEGNO are used and manufactured according to an individual design made by a structural engineer responsible for the design of works on a case by case basis. Wood-concrete composite floors may function as directly load bearing and structural bracing members. The structural performance of them shall be considered in accordance with the limit state design principles specified in Eurocodes.</p> <p>The performance of the composite slab is outside of this ETA.</p> <p>Mechanical properties of LATERLITE CONNETTORE CENTROSTORICO LEGNO and applicable creep and duration of load factors for composite members are given in Annex 2.</p>
Corrosion protection	The screws are made of case hardened steel as specified in the control plan and corrosion protected with a zinc coating.
3.2 Safety in case of fire (BWR 2)	
Reaction to fire	LATERLITE CONNETTORE CENTROSTORICO LEGNO including the zinc coating are classified as A1 in accordance with EN 13501-1 and Commission Delegated Regulation 2016/364.

*) See additional information in section 3.3 – 3.4.

3.3 General aspects

Laterlite S.p.A delivers connectors intended to be component in wood-concrete composite slabs in accordance with the provisions of this European Technical Assessment. The LATERLITE CONNETTORE CENTROSTORICO LEGNO connectors are manufactured in the factory in

accordance with the provisions of this European Technical Assessment.

LATERLITE CONNETTORE CENTROSTORICO LEGNO connectors shall be installed on the basis of a specific structural design for each composite slab installation. Load bearing capacities to be used in the design are given in Annex 2.

The design also shall take into account any aspects regarding installation of the kit components, as any temporary bracing and supporting. Wood-concrete composite slabs shall be installed by appropriately qualified personnel, following the installation plan. Only LATERLITE CONNETTORE CENTROSTORICO LEGNO connectors without any defects are allowed to be used. Before concrete is poured, the person responsible for the design of the works shall check the set of the LATERLITE CONNETTORE CENTROSTORICO LEGNO connectors to be in accordance with the design. The manufacturer shall ensure that the information of these provisions is given to those concerned.

3.10 Aspects related to the performance of the product

3.10.1 Corrosion protection in service class 1 and 2.
Durability of the finished composite slab is not covered by this ETA.

Durability of the LATERLITE CONNETTORE CENTROSTORICO LEGNO connectors is provided for by the protective zinc coating for a mean thickness of 5 µm.

4 Attestation and verification of constancy of performance (hereinafter AVCP) system applied, with reference to its legal base

4.1 AVCP system

According to the decision 2000/447/EC of the European Commission, the system(s) of assessment and verification of constancy of performance (see Annex V to Regulation (EU) No 305/2011) is 1.

5 Technical details necessary for the implementation of the AVCP system, as provided for in the applicable EAD

Technical details necessary for the implementation of the AVCP system are laid down in the control plan deposited at ETA-Danmark prior to CE marking

Issued in Copenhagen on 2024-08-02 by

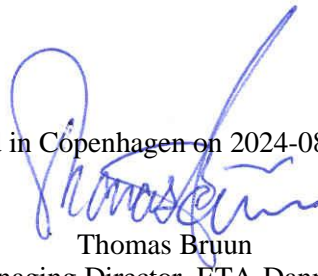

Thomas Bruun
Managing Director, ETA-Danmark

ANNEX 1
WOOD-CONCRETE COMPOSITE SLAB COMPOSED WITH LATERLITE CONNETTORE
CENTROSTORICO LEGNO CONNECTORS
Tolerances and materials held on file by ETA-Danmark A/S

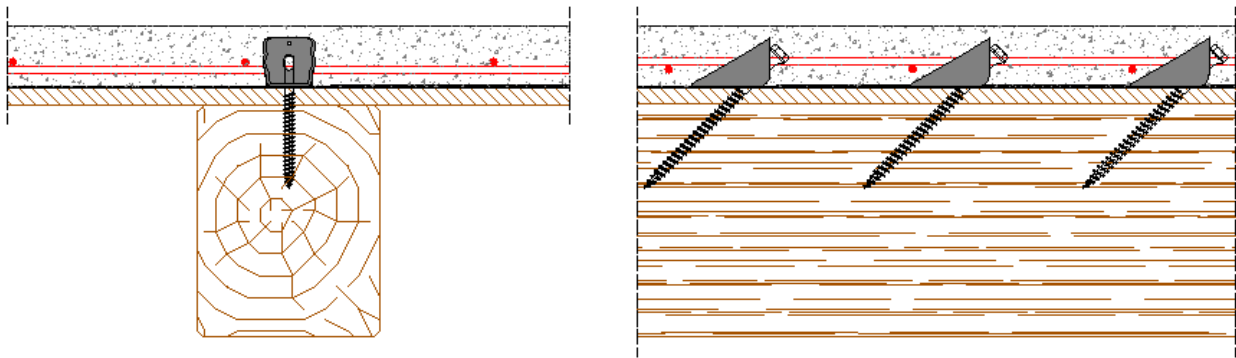

Figure 1.1a
Elevation on (right) and cross-section through (left) a composite member with LATERLITE CONNETTORE CENTROSTORICO LEGNO connector.

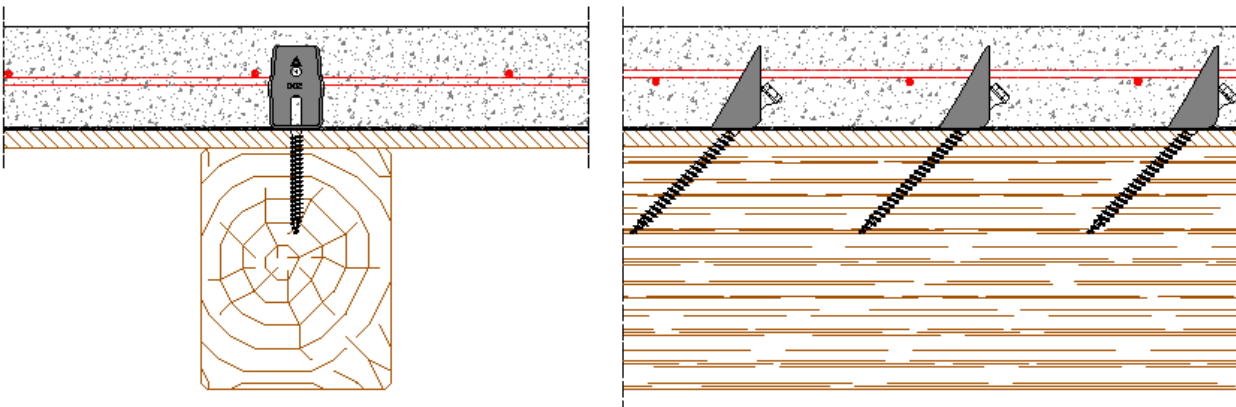

Figure 1.1b
Elevation on (right) and cross-section through (left) a composite member with LATERLITE CONNETTORE CENTROSTORICO LEGNO connector.

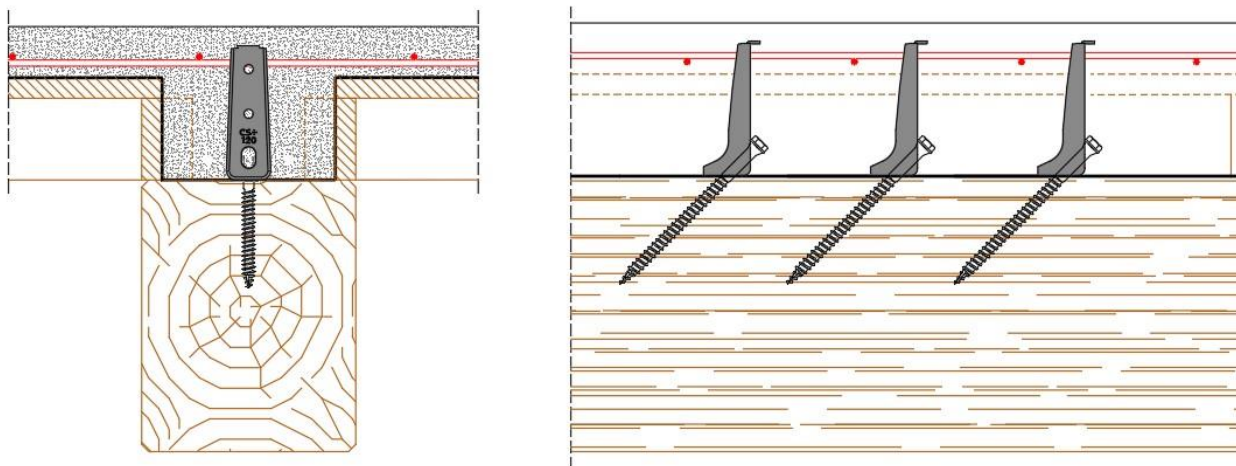

Figure 1.1c
Elevation on (right) and cross-section through (left) a composite member with LATERLITE CONNETTORE CENTROSTORICO LEGNO H120 connector

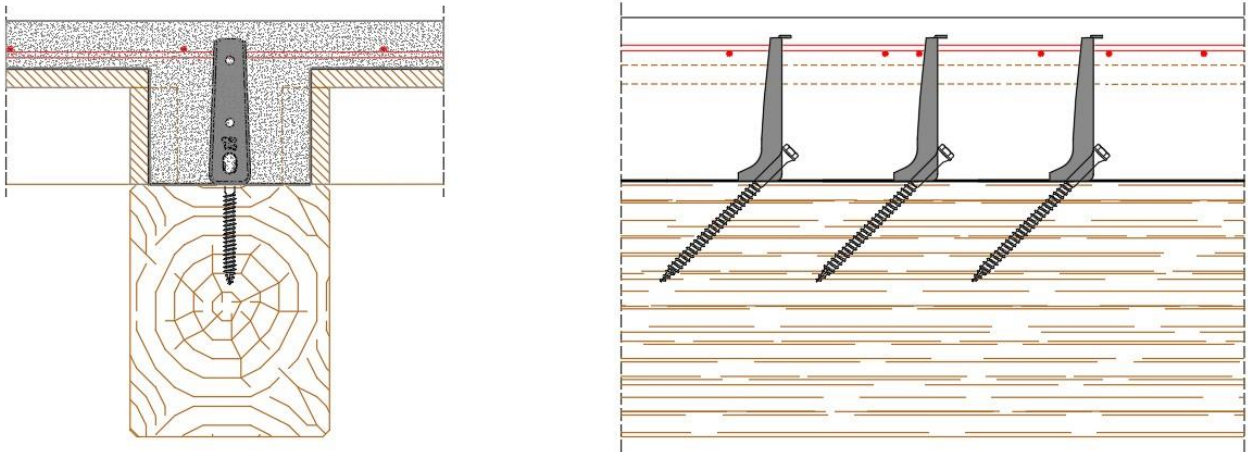

Figure 1.1d
Elevation on (right) and cross-section through (left) a composite member with LATERLITE CONNETTORE CENTROSTORICO LEGNO H140 connector.

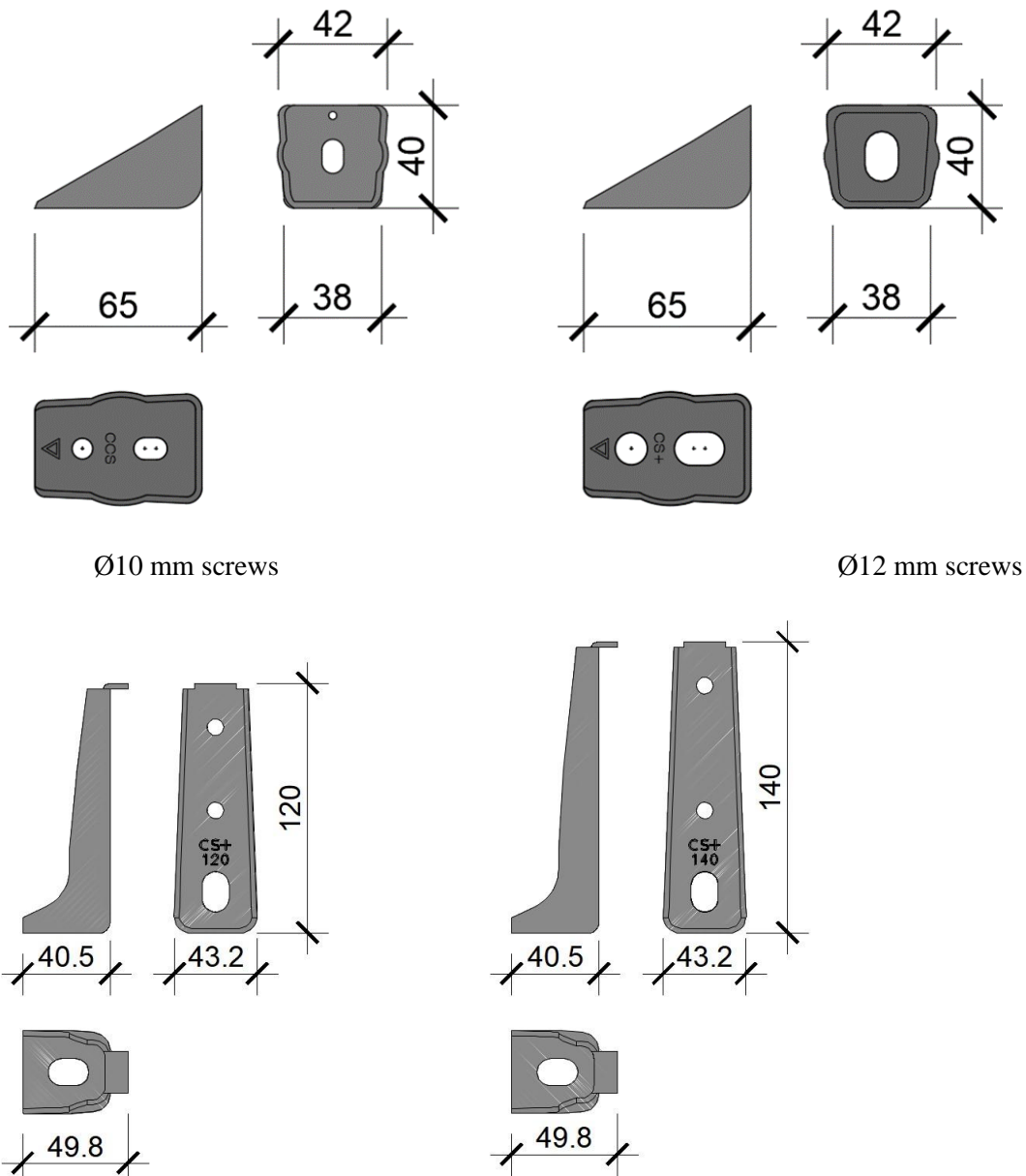

Figure 1.1.e LATERLITE CONNETTORE CENTROSTORICO LEGNO without screw

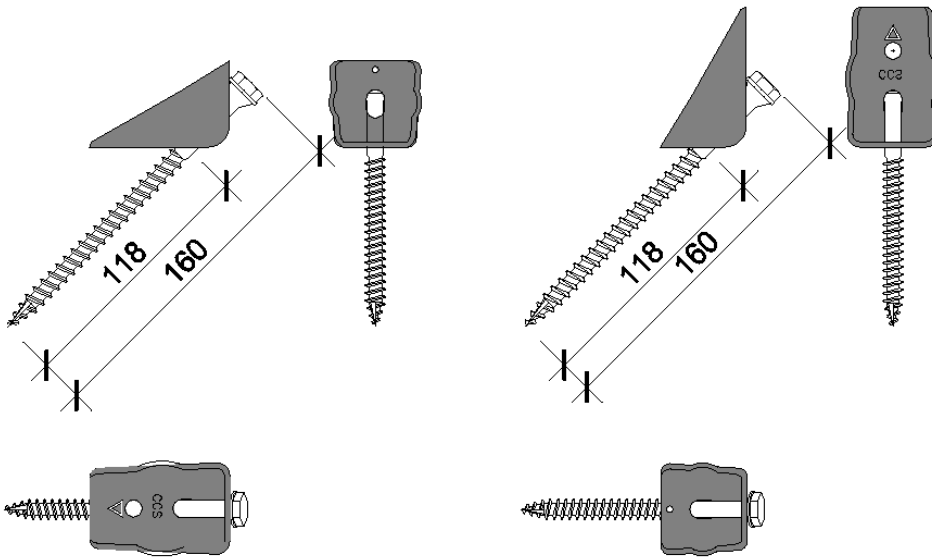

Figure 1.1.f LATERLITE CONNETTORE CENTROSTORICO LEGNO with 10x160 screw in two possibly configurations

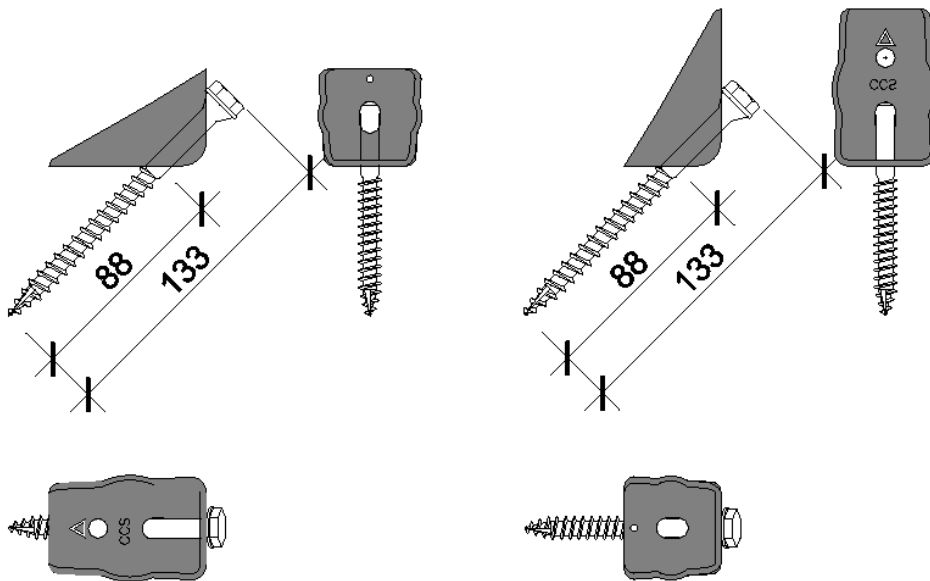

Figure 1.1.g LATERLITE CONNETTORE CENTROSTORICO LEGNO with 10x133 screw in two possibly configurations

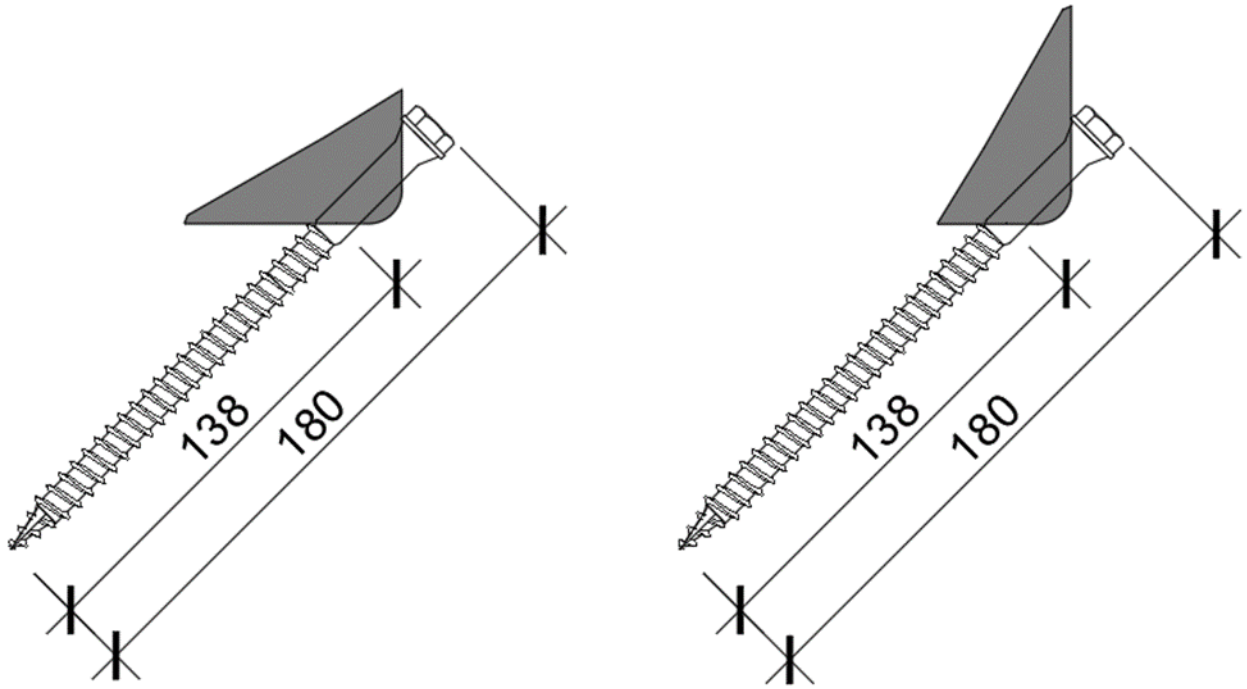
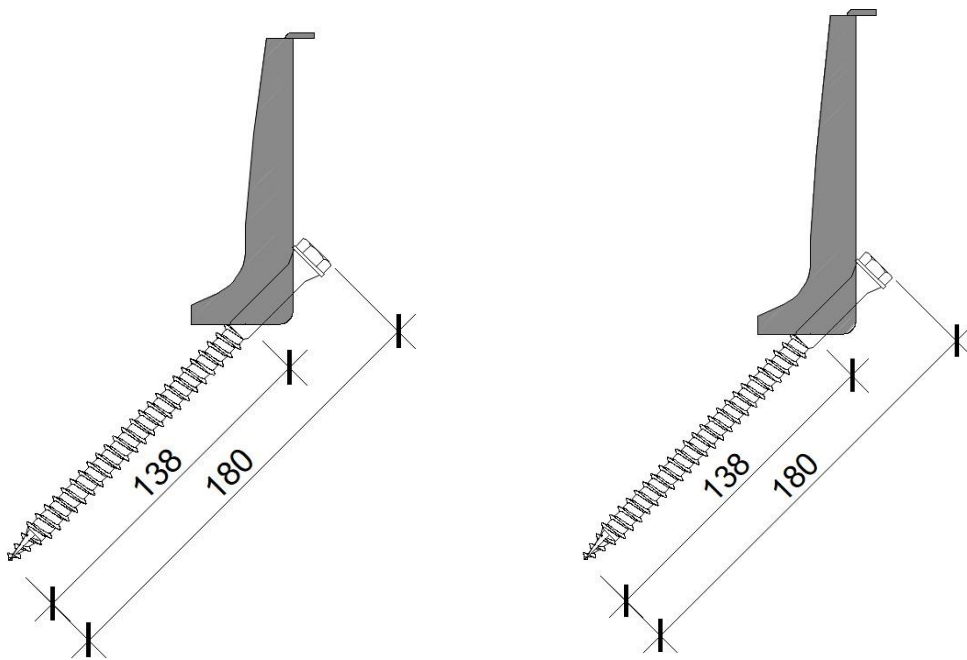

Figure 1.1.h LATERLITE CONNETTORE CENTROSTORICO LEGNO with 12x180 screw in two possibly configurations



LEGNO H120

LEGNO H140

Figure 1.1.i LATERLITE CONNETTORE CENTROSTORICO LEGNO with 12x180 screw in two possible configurations

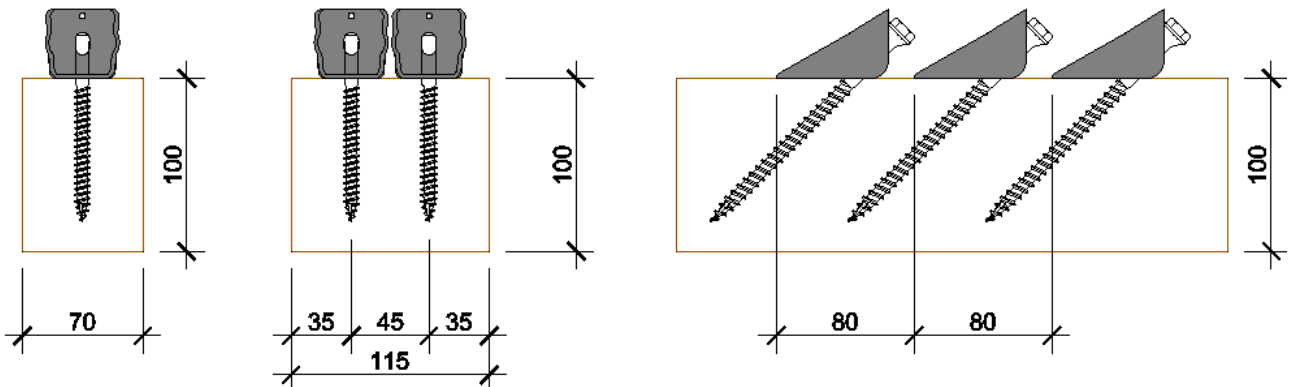

Figure 1.1.j Minimum distances and dispositions for LATERLITE CONNETTORE CENTROSTORICO LEGNO connector with screw 10x160 and wood with density < 420 kg/m³

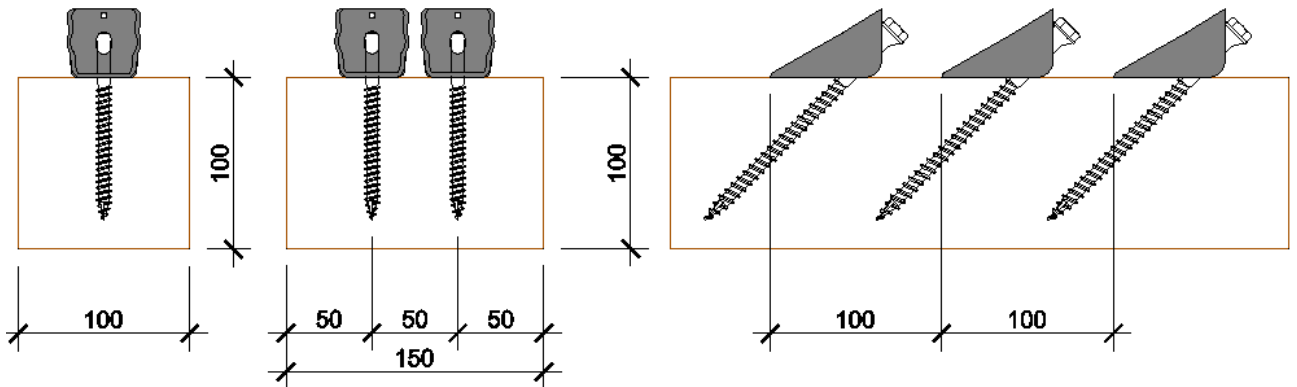

Figure 1.1.k Minimum distances and dispositions for LATERLITE CONNETTORE CENTROSTORICO LEGNO connector with screw 10x160 and wood with density < 500 kg/m³

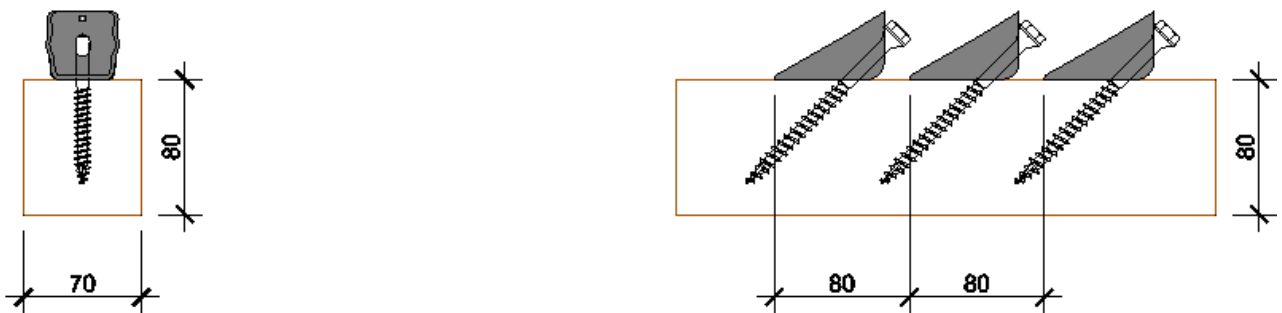

Figure 1.1.l Minimum distances and dispositions for LATERLITE CONNETTORE CENTROSTORICO LEGNO connector with screw 10x133 and wood with density < 420 kg/m³

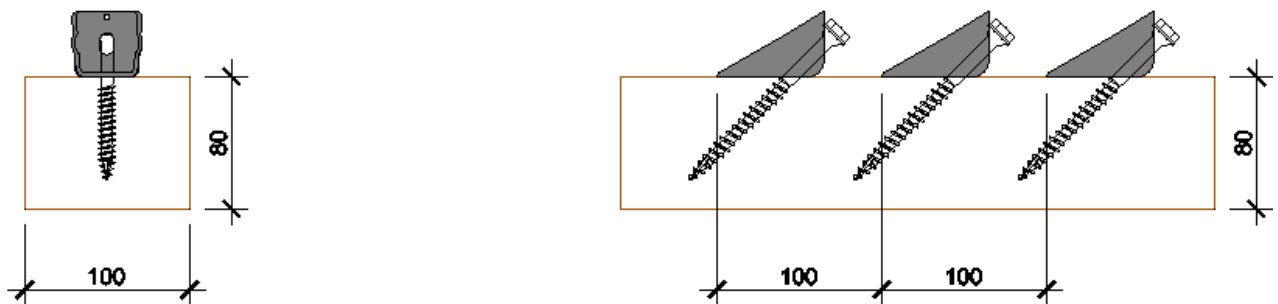

Figure 1.1.m Minimum distances and dispositions for LATERLITE CONNETTORE CENTROSTORICO LEGNO connector with screw 10x133 and wood with density < 500 kg/m³

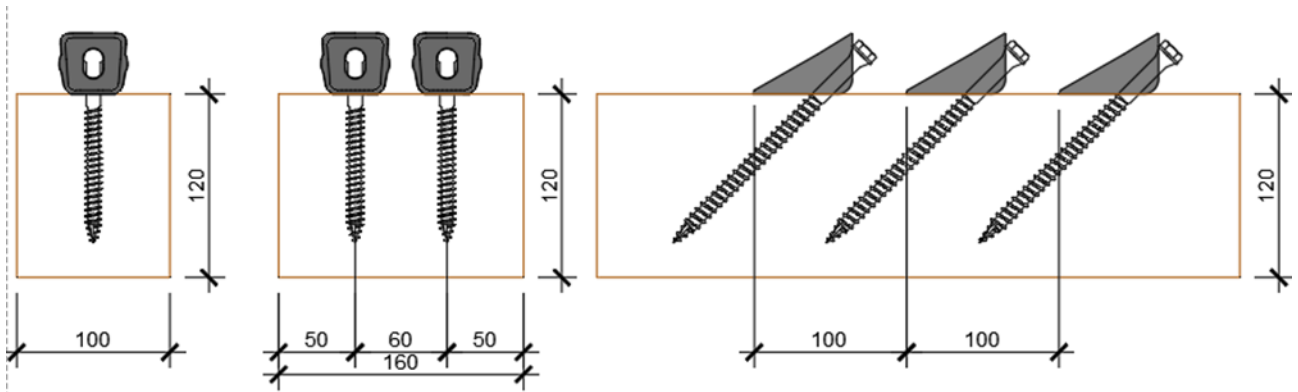

Figure 1.1.n Minimum distances and dispositions for LATERLITE CONNETTORE CENTROSTORICO LEGNO connector with screw 12x180

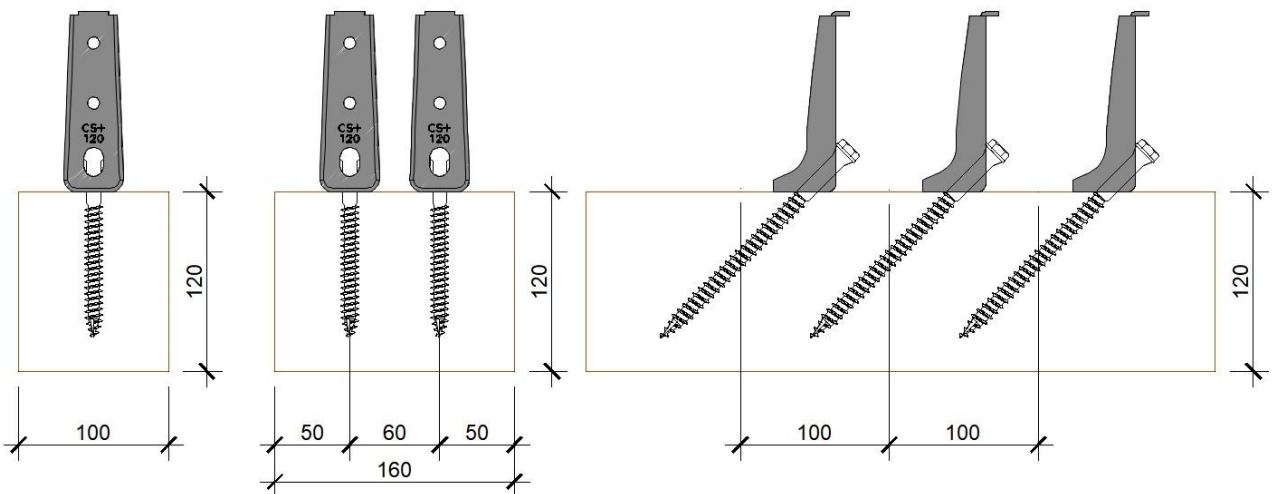

Figure 1.1.o Minimum distances and dispositions for LATERLITE CONNETTORE CENTROSTORICO LEGNO H120 connector with screw 12x180

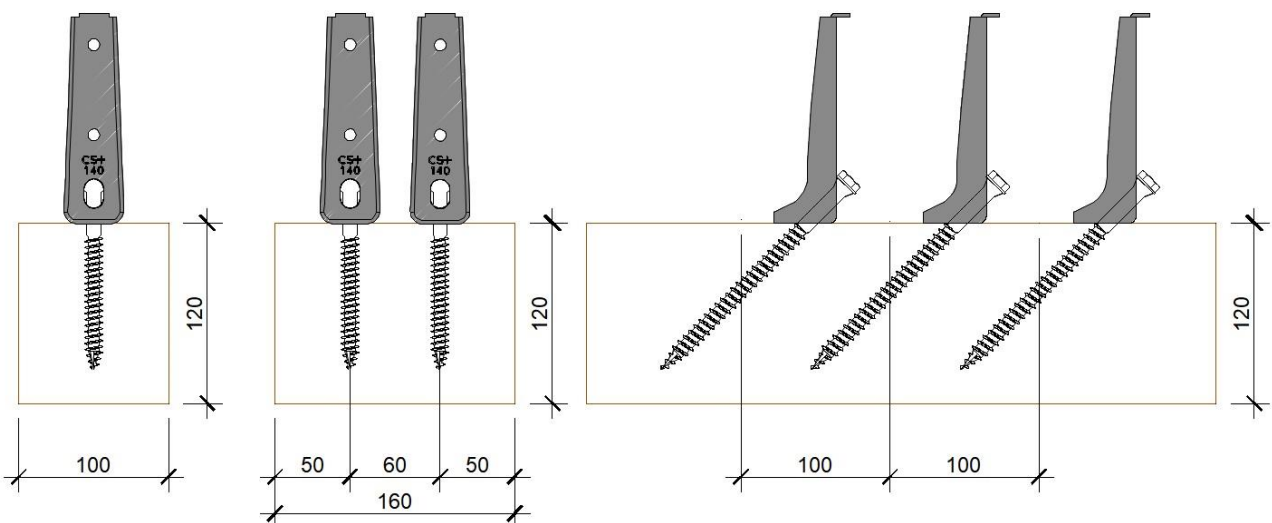

Figure 1.1.p Minimum distances and dispositions for LATERLITE CONNETTORE CENTROSTORICO LEGNO H140 connector with screw 12x180

The composition of the screw materials is deposited at ETA-Denmark.

The length and diameter of the screws is given in Annex 3. More exact description of the shape and tolerances of the screws are in the Control Plan.

ANNEX 2

MECHANICAL PROPERTIES

Resistance and stiffness

Structural model

Composite members with LATERLITE CONNETTORE CENTROSTORICO LEGNO Connectors are to be designed taking into account the influence of the slip occurring in the joints. A method for the calculation of the load bearing capacity and the deformation of mechanically jointed beams or columns is given in Annexes B and C of Eurocode 5 Part 1-1: General – Common rules and rules for buildings. Calculations should be carried out assuming a linear relationship between force and slip. Alternative methods for the calculation based on numerical models are also applicable.

For the determination of the internal forces and moments an elastic behaviour of the concrete may be assumed if the tensile stress in the concrete does not exceed twice the concrete tensile strength.

Apart from the design of the composite member, the load-carrying-capacity of the concrete layer spanning between the timber beams should be checked. If the floor is supported by the timber beams, the shear capacity of the timber should also be checked, otherwise, if the floor is supported by the concrete slab, the shear capacity of the slab should be checked..

The support of the wood concrete composite elements shall be carried out via the lower cross-sectional part either directly by contact or by appropriate connections.

Design of the wood-concrete composite slab

The long-term effects (e.g. shrinkage of the concrete, dimensional changes of timber, creep) shall be verified by calculation. Concrete and timber properties and models as used in verifications of long-term effects should be based on EN 1992 1-1 and EN 1995-1-1 considering the environmental and climatic conditions in place of use.

The influence of creep and moisture changes may be taken into account by reducing the modulus of elasticity of the timber and concrete and the slip modulus to be used in calculations analogous with EN 1995-1-1 and with EN1992-1-1.

The values of the deformation factors k_{def} for timber and LATERLITE CONNETTORE CENTROSTORICO LEGNO connectors should be taken from EN 1995-1-1. The values of the deformation factor φ for concrete should be taken from EN 1992-1-1. For floors in service class = 1, φ for concrete can be taken = 2.5. For prefabricated concrete slabs, the concrete shrinkage may be disregarded.

Values of characteristic shear resistance $F_{v,Rk}$, slip modulus K_{ser} and K_u of the connectors

Connector	Decking	Wood	$F_{v,Rk}$	K_{ser}	K_u
			kN	kN/mm	kN/mm
LATERLITE CONNETTORE CENTROSTORICO LEGNO Screw 10x160	absent	C16 and +	14,060	19.340	16,990
		C24 and + GL24 and + D18 and +	15,500		
	20mm	C16 and +	13,230	12.670	12.670
		C24 and + GL24 and + D18 and +	14,580		
	40mm	C16 and +	10,190	9.200	9.200
		C24 and + GL24 and + D18 and +	11,230		

Connector	Decking	Wood	$F_{v,Rk}$	K_{ser}	K_u
			kN	kN/mm	kN/mm
LATERLITE CONNETTORE CENTROSTORICO LEGNO Screw 10x133	absent	C16 and + C24 and + GL24 and + D18 and +	10,110	7,137	6,691
	25mm	C16 and + C24 and + GL24 and + D18 and +	8,290	9,254	8,908

Connector	Decking	Wood	$F_{v,flk}$	K_{ser}	K_{w}
			kN	kN/mm	kN/mm
LATERLITE CONNETTORE CENTROSTORIC O LEGNO Screw 12x180	absent	C14	19,880	20,900	15,570
		C16	20,970		
		C18	21,510		
		C20	22,050		
		C22	22,580		
		C24	23,110		
		C27	23,640		
		C30	24,690		
		C35 and +	24,950		
		D18 and +	24,950		
		GL20c	23,380		
		GL22c	23,380		
		GL24c	23,900		
		GL26c and +	24,950		
		GL20h	22,580		
	GL22h	24,160			
	GL24h and +	24,950			
	20 mm	C14	17,140	17,030	17,030
		C16	18,080		
		C18	18,550		
		C20	19,010		
		C22	19,470		
		C24	19,330		
		C27	20,380		
		C30	21,280		
		C35 and +	21,510		
		D18 and +	21,510		
		GL20c	20,150		
		GL22c	20,150		
		GL24c	20,610		
		GL26c and +	21,510		
		GL20h	19,470		
	GL22h	20,830			
	GL24h and +	21,510			
	40 mm	C14	13,180	11,810	11,810
		C16	13,900		
		C18	14,260		
		C20	14,620		
		C22	14,970		
		C24	15,320		
		C27	15,670		
		C30	16,360		
		C35 and +	16,540		
		D18 and +	16,540		
		GL20c	15,500		
GL22c		15,500			
GL24c		15,840			
GL26c and +		16,540			
GL20h		14,970			
GL22h	16,020				
GL24h and +	16,540				

Resistance to fire

Simplified rules in EN 1995-1-2 for calculation of resistance to fire in case of screws are applicable for constructions made by LATERLITE CONNETTORE CENTROSTORICO LEGNO, LATERLITE CONNETTORE CENTROSTORICO LEGNO H120 and LATERLITE CONNETTORE CENTROSTORICO LEGNO H140 Connectors.

Thus, in design of works, fire resistance of the timber members may be determined according to EN 1995-1-2 and the fire resistance of the concrete flange according to EN 1992-1-2, if the national rules allow for calculation.